

Moulded Bench Assembly Instructions

PLEASE READ THESE INSTRUCTIONS CAREFULLY AND FOLLOW THE ASSEMBLY DRAWINGS.
WE WILL NOT ACCEPT ANY CLAIMS IF THIS PRODUCT IS WRONGLY ASSEMBLED.



Parts Supplied

- a) 2 × Leg frames
- b) 5 × Seat and back slats [numbered 1 to 5]
- c) 16 × 90mm long screws
- d) 4 × 70mm long screws

Tools Required

- Power drill with Philips screw driver bit
- Measuring tape
- Straight edge

2 Person Operation

All seat and table slat labels should face upward and be on the left-hand side when assembled. A-Frame labels should face outwards.

1.

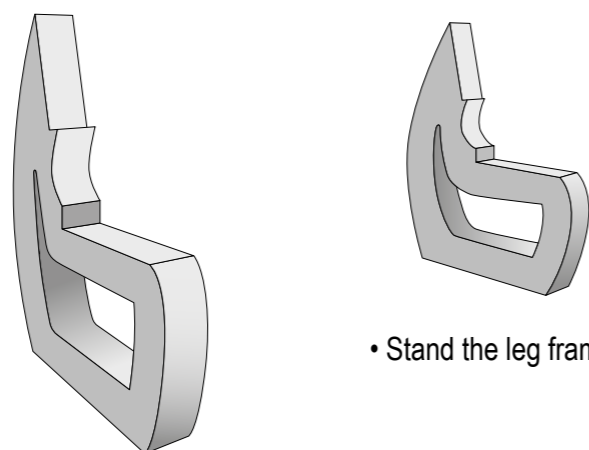

- Stand the leg frames upright on a flat surface.

2.

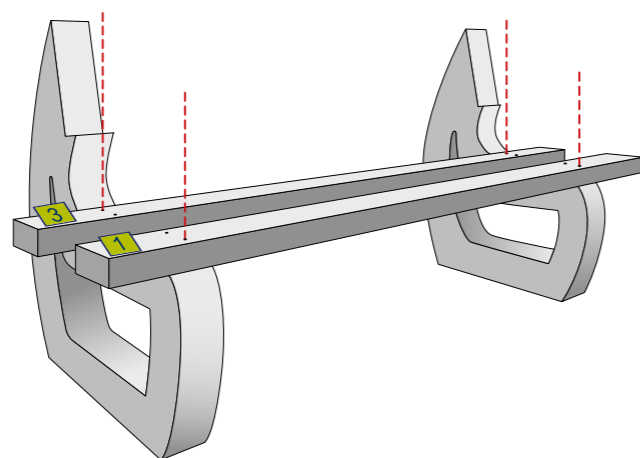

- 2 × Seat slats [1&3]
- 8 × 90mm screws

- Position the outer and inner seat slats [1&3], ensuring that there is enough space for the central slat with about 25mm gaps between slats.
- Position the inner seat slat flush with the back support.
- The outer seat slat will overhang the front of the leg frame.
- Line up the screw holes with the centre of the frames.
- Square the ends with a straight edge.
- Fix the outer holes with 90mm screws.
- Ensure that the frames are square by measuring across the diagonals.
- Fix the remaining 90mm screws.

3.

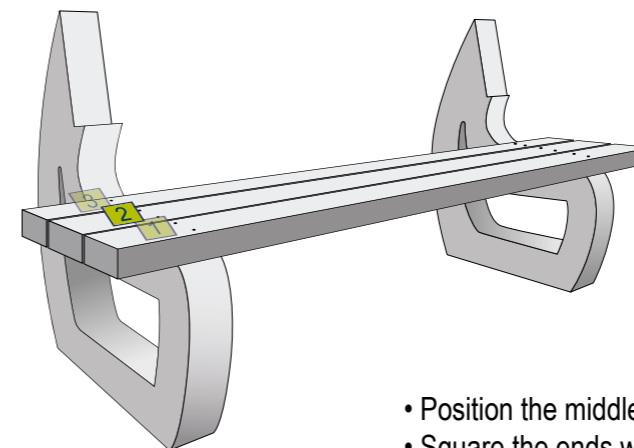

- 1 × Seat slat [2]
- 4 × 90mm screws

- Position the middle seat slat [2] with equal gaps.
- Square the ends with a straight edge.
- Fix with 90mm screws.

4.

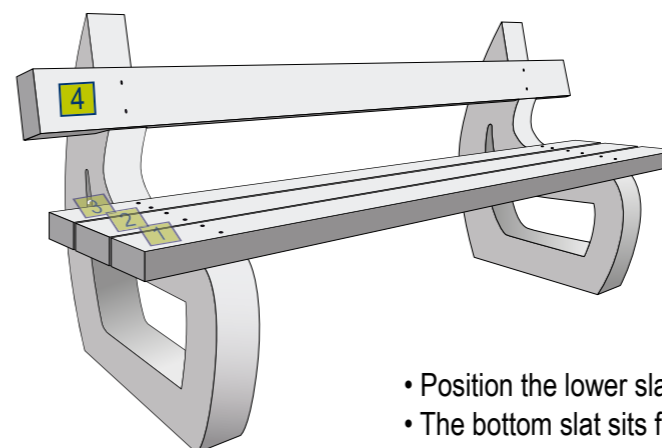

- 1 × Back slat [4]
- 4 × 90mm screws

- Position the lower slat [4] on the back.
- The bottom slat sits flush with the back support.
- Fix the bottom slat with with 90mm screws.

5.

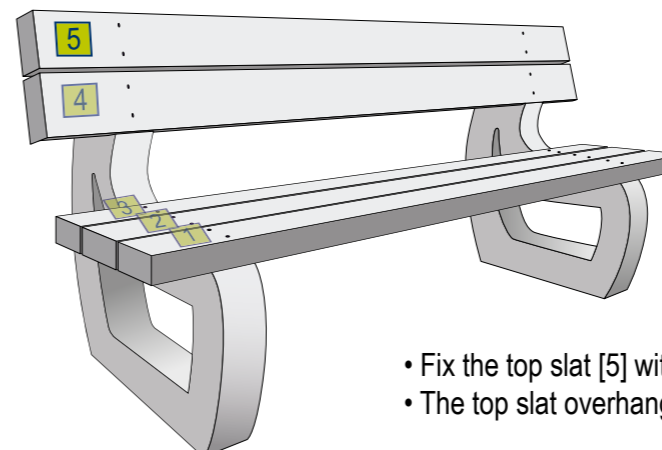

- 1 × Back slat [5]
- 4 × 70mm screws

- Fix the top slat [5] with 70mm screws.
- The top slat overhangs the top of the back support.