

Metal Frame Bench Assembly Instructions

PLEASE READ THESE INSTRUCTIONS CAREFULLY AND FOLLOW THE ASSEMBLY DRAWINGS.
WE WILL NOT ACCEPT ANY CLAIMS IF THIS PRODUCT IS WRONGLY ASSEMBLED.

Parts Supplied

- a) 3 × Leg frames
- b) 3 × Seat slats with 3 pre-drilled holes
- c) 2 × Back slats with 3 pre-drilled holes
- d) 15 × M10 × 110mm bolts
- e) 15 × M10 nuts
- f) 15 × Washers
- g) 15 × Plastic covers

Tools Required

- 17mm Socket wrench
- Measuring tape

2 Person Operation

**Standard
Black**

1.

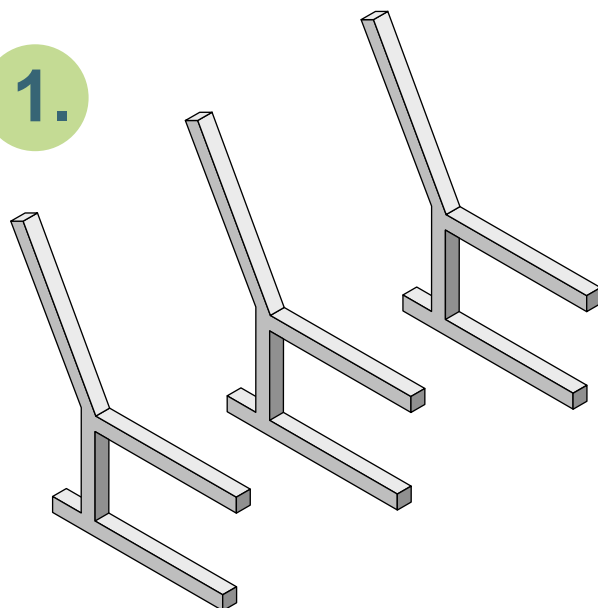

3 × Leg Frames

- Stand leg frames upright on a flat surface.

2.

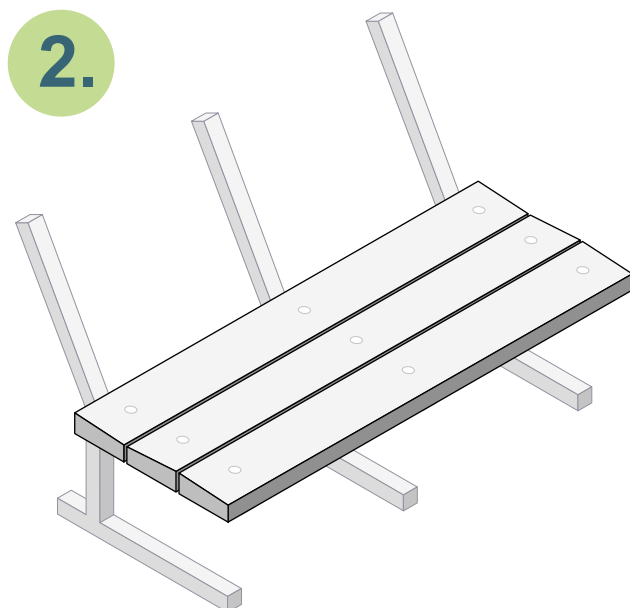

3 × Seat slats
9 × Bolts
9 × Washers
9 × Nuts

- Position the seat slats on the frames with the slats angled as shown in Diagram A.
- Line up the bolt holes on the frames and fix the outer holes with the bolts.
- Ensure that the frames are square by measuring across the diagonals. The diagonals should measure the same.
- Fix the remaining bolts.
- Put on the washers and the nuts, hand tighten only.

3.



2 × Back slats
6 × Bolts
6 × Washers
6 × Nuts

- Position the back slats on the frames with the slats angled as shown in Diagram A.
- Line up the bolt holes and fix with the bolts.
- Put on the washers and the nuts, see Diagram B, hand tighten only.

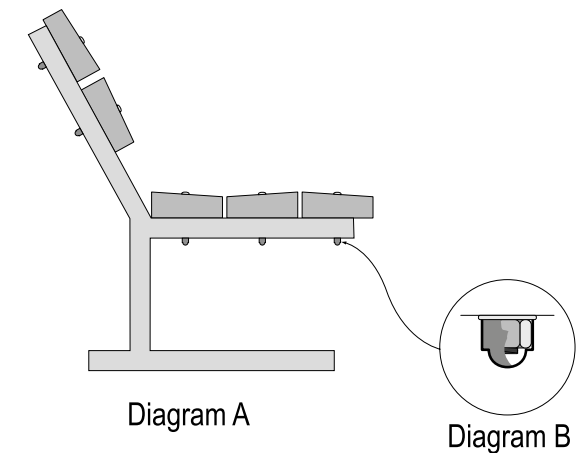

4.



15 × Plastic covers

- Tighten up all the nuts with the 17mm socket wrench.
- Put plastic covers on all the nuts.