

PARTS LIST - 2 PERSON ASSEMBLY:-

A	PRE-ASSEMBLED TABLE + FRAME	1 no.
B	PRE-ASSEMBLED SEAT	4 no.
C	M10 x 160mm BOLT	4 no.
D	M10 x 90mm COACH SCREW	4 no.
E	WASHER	8 no.
F	M10 NUT	4 no.
G	CAP	8 no.

TOOLS:-

HAMMER
17mm SPANNER

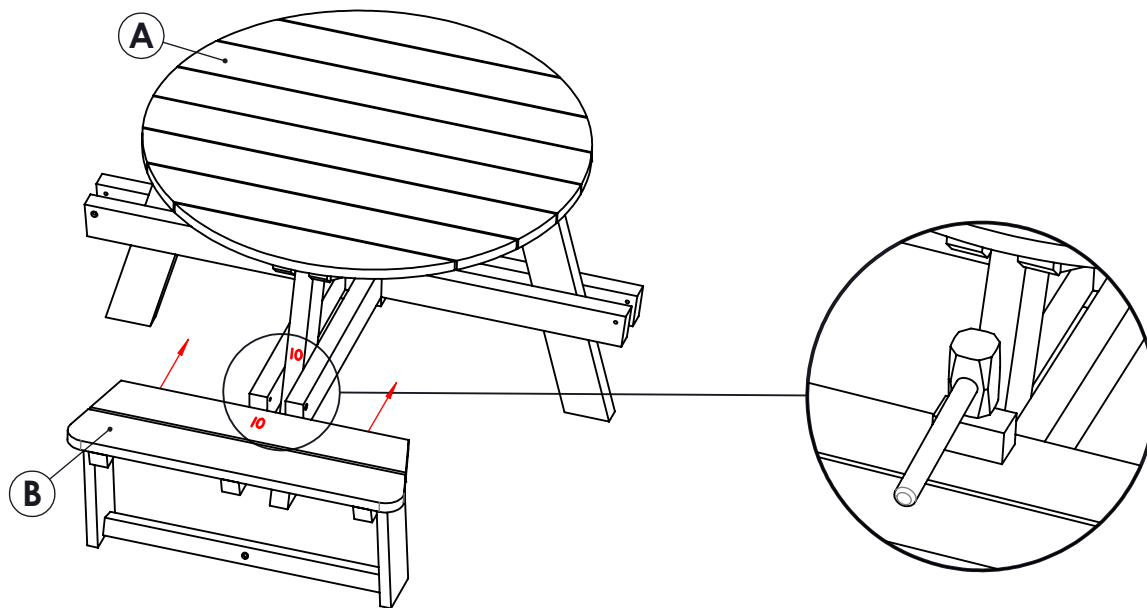

IDENTIFY SEAT VIA IT'S NUMBER AND MATCH IT TO TABLE LEG WITH THE SAME NUMBER, WIPE OFF NUMBER WITH WATER ONCE SEAT IS IN PLACE.

POSITION SEAT FORWARD AND UP TIGHT AGAINST THE TABLE LEG, POSITION THE SEAT TIE LOCATED UNDER THE SEAT IN BETWEEN THE TABLE FRAME BRACES. THE SEAT WILL THEN NEED TO BE HAMMERED INTO PLACE, PLEASE USE BLOCK PROVIDED TO DO SO AND AVOID DAMAGING YOUR SEAT.

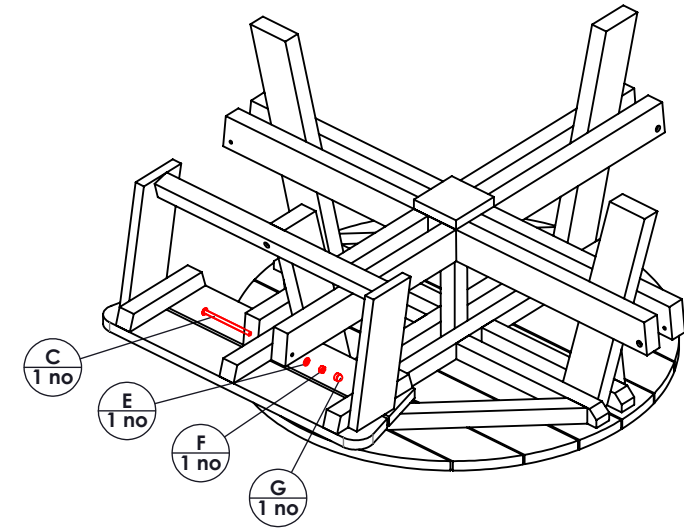

TABLE SHOWN UPSIDE DOWN FOR ILLUSTRATION PURPOSES ONLY.

USING A PROVIDED M10 x 160mm BOLT, FIX THE BOLT THROUGH PRE-DRILLED HOLES IN SEAT TIE AND TABLE FRAME BRACES, ADD WASHER AND NUT AND TIGHTEN UP, COVER NUT WITH BLACK CAP.

Help and support:-

Please contact us using the telephone number or email address as stated on your shipping documents.

ROUND PICNIC TABLE: Assembly Guide - 1 of 2

TOOLS:-**HAMMER****17mm SPANNER****IMPORTANT:-**

Ensure that you are familiar with these assembly instructions prior to commencing assembly.

We will not accept any claims resulting from products that have been wrongly assembled.

Employ safe lifting procedures when handling components.

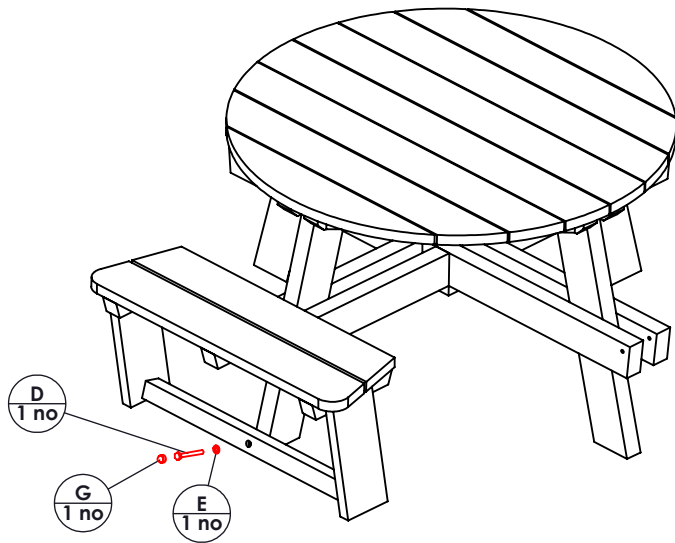

USE PROVIDED M10 x 90mm COACH SCREW,
ADD WASHER AND FIX SEAT BOTTOM TO
TABLE LEG VIA THE PRE-DRILLED HOLE.
COVER NUT WITH BLACK CAP.

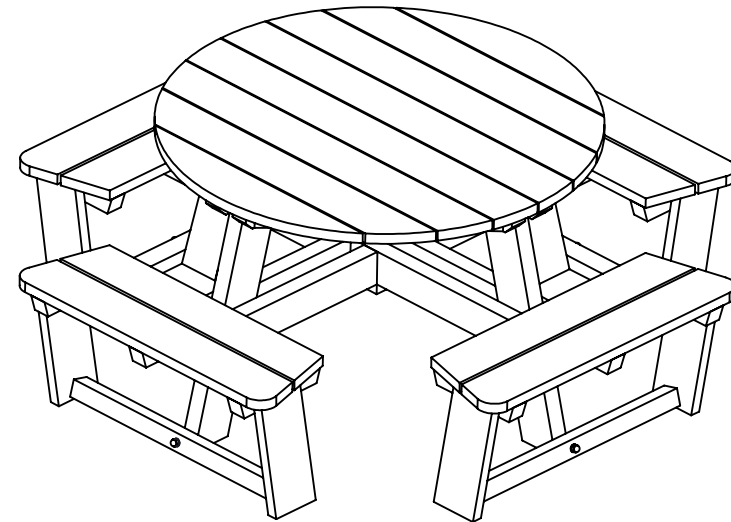

SEAT ASSEMBLY SHOULD NOW BE
REPEATED FOR THE REMAINING 3 SEATS,
THIS SHOULD FINISH TABLE ASSEMBLY.

Help and support:-

Please contact us using the telephone number
or email address as stated on your shipping documents.

ROUND PICNIC TABLE: Assembly Guide - 2 of 2