

PARTS LIST - 2 PERSON ASSEMBLY:-		
A	LEG FRAMES	2 no.
B	SEAT SLATS [NUMBERED 1 TO 4]	4 no.
C	90MM LONG SCREWS	12 no.
D	70MM LONG SCREWS	4 no.

TOOLS:-
POWER DRILL WITH PHILIPS-HEAD BIT
MEASURING TAPE
STRAIGHT EDGE

ALL SEAT SLAT LABELS SHOULD FACE UPWARD AND BE ON THE LEFT-HAND SIDE WHEN ASSEMBLED.

**IMPORTANT:-**

Ensure that you are familiar with these assembly instructions prior to commencing assembly.

We will not accept any claims resulting from products that have been wrongly assembled.

Employ safe lifting procedures when handling components.

1

2 " Leg frames

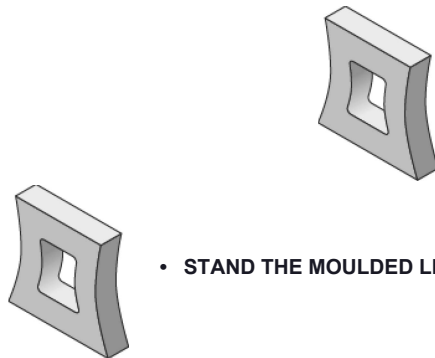

- STAND THE MOULDED LEG FRAMES UPRIGHT ON A FLAT SURFACE

2

4 x Seat slats  
4 " 70mm screws  
12 x 90mm screws

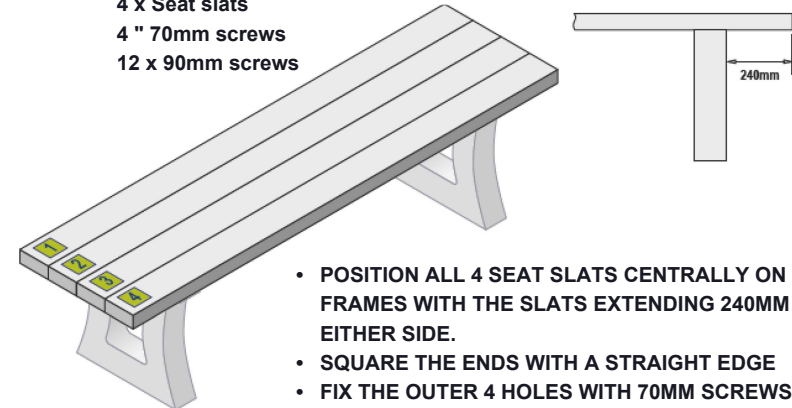

- POSITION ALL 4 SEAT SLATS CENTRALLY ON THE FRAMES WITH THE SLATS EXTENDING 240MM ON EITHER SIDE.
- SQUARE THE ENDS WITH A STRAIGHT EDGE
- FIX THE OUTER 4 HOLES WITH 70MM SCREWS.
- ENSURE THAT THE FRAMES ARE SQUARE BY MEASURING ACROSS THE DIAGONALS. THE DIAGONALS SHOULD MEASURE THE SAME.
- FIX THE REMAINING HOLES WITH 90MM SCREWS.

Please contact us if you need any further help or information.

**OAKWORTH BENCH –  
COLOURED SLATS**

Unit 8C, Top Land Country Business Park  
Cragg Road, Mytholmroyd, Hebden Bridge,  
West Yorkshire, HX7 5RW  
Phone: 01422 419 555  
Mail: [info@britishrecycledplastic.co.uk](mailto:info@britishrecycledplastic.co.uk)

BRITISH  
RECYCLED  
PLASTIC 