

PARTS LIST - 2 PERSON ASSEMBLY:-

A	PRE-ASSEMBLED TABLE TOP	1 no.
B	END A-FRAME	2 no.
C1	CUT END A-FRAME	1 no.
D	PRE-ASSEMBLED SEAT	1 no.
D1	PRE-ASSEMBLED SEAT (600)	1 no.
E	70mm BRASS SCREWS	62 no.
F	70mm S/STEEL SCREWS	22 no.

TOOLS:-

POWER DRILL WITH PHILIPS-HEAD BIT

MEASURING TAPE & STRAIGHT EDGE

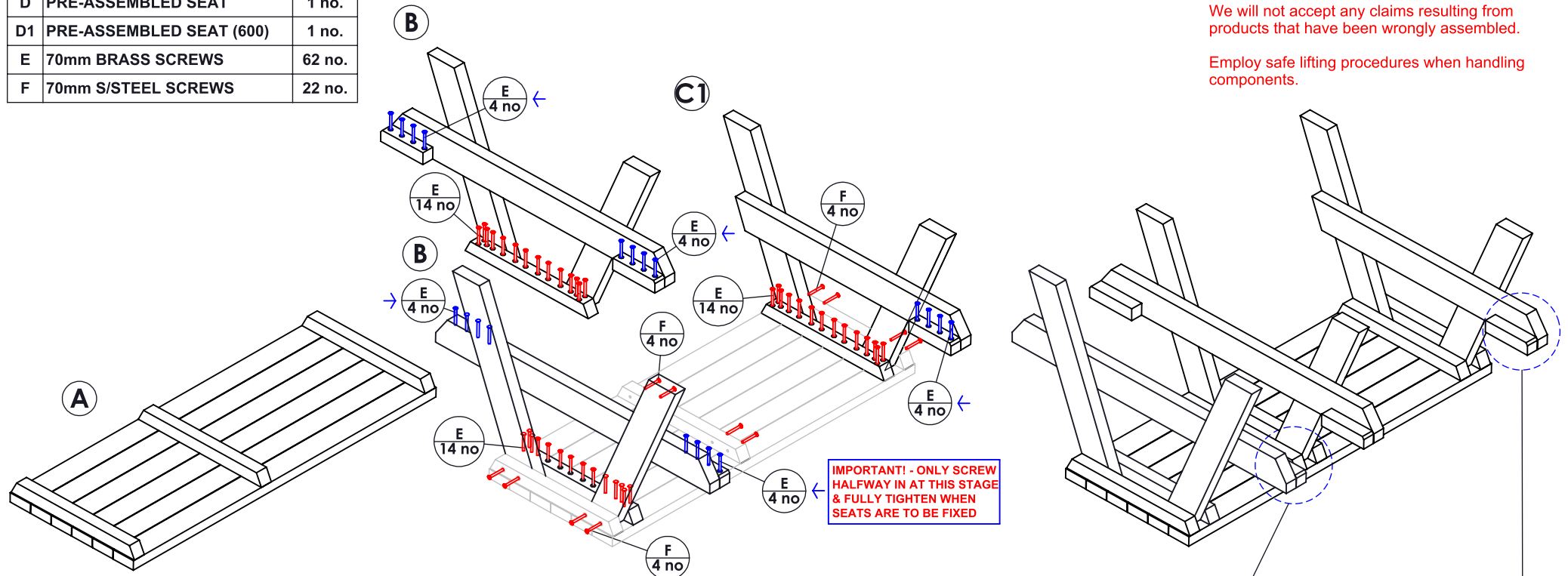

BEGIN ASSEMBLY WITH TABLETOP TURNED UPSIDE-DOWN.

FIX A-FRAMES TO TABLETOP USING 70mm SCREWS THROUGH PRE-DRILLED HOLES IN FIXING BARS.

BEFORE FULLY TIGHTENING ALL SCREWS, CHECK THAT THE SEATS ARE SQUARE BY MEASURING ACROSS THE DIAGONALS. BOTH DIAGONAL MEASUREMENTS SHOULD BE EQUAL.

ENSURE END A-FRAMES HAVE THE SEAT FIXING BLOCKS FACING INWARDS, AS SHOWN. ENSURE ALSO THAT THE CROSS-BAR OF THE MIDDLE A-FRAME IS FACING THE CROSS-BAR OF THE NEAREST END A-FRAME.

IMPORTANT:-

Ensure that you are familiar with these assembly instructions prior to commencing assembly.

We will not accept any claims resulting from products that have been wrongly assembled.

Employ safe lifting procedures when handling components.

Please contact us if you need any further help or information.

BRADSHAW PICNIC TABLE**Assembly Guide - 1 of 2**

Unit 8C, Top Land Country Business Park
Cragg Road, Mytholmroyd, Hebden Bridge,
West Yorkshire, HX7 5RW
Phone: 01422 419 555
Mail: info@britishrecycledplastic.co.uk

**BRITISH
RECYCLED
PLASTIC**

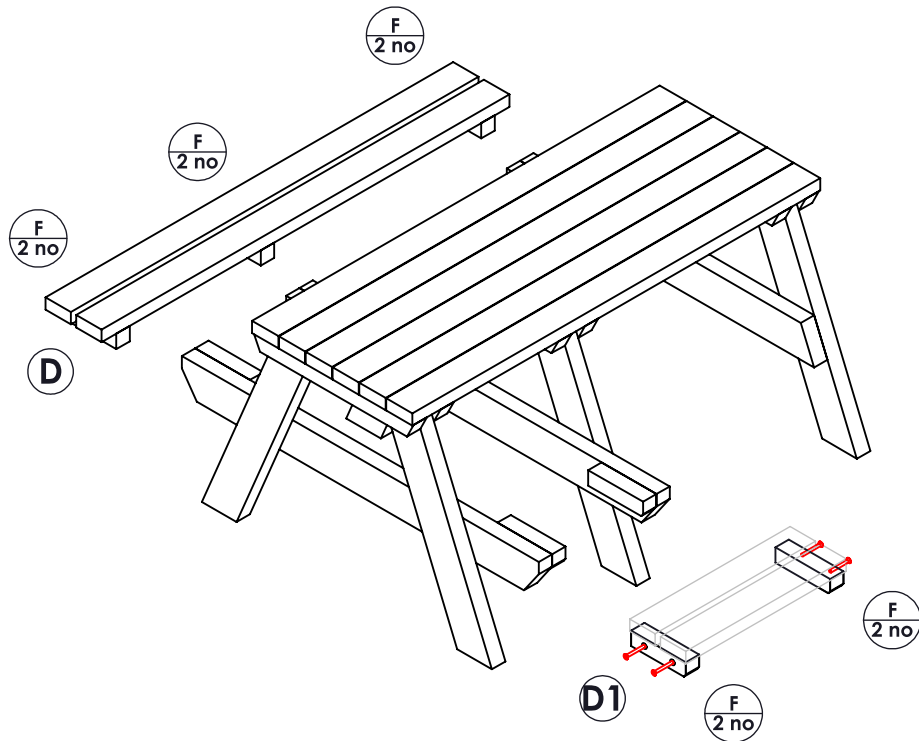

TOOLS:-**POWER DRILL WITH PHILIPS-HEAD BIT****MEASURING TAPE & STRAIGHT EDGE**

TURN PICNIC TABLE OVER ONTO FEET AND FIX PRE-ASSEMBLED SEATS USING 70mm SCREWS THROUGH PRE-DRILLED HOLES IN SEAT FIXING BLOCKS.

IMPORTANT - ENSURE THAT THE 20 no BRASS SEAT FIXING SCREWS ARE NOW FULLY TIGHTENED - THESE ARE SHOWN ON PAGE 1 OF 2

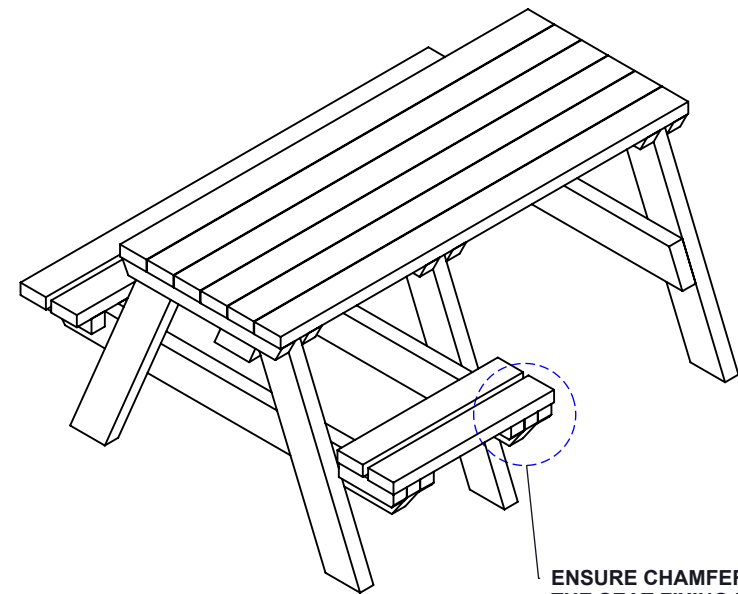

ENSURE CHAMFERED ENDS OF THE SEAT FIXING BLOCKS ARE FACING OUTWARDS, AS SHOWN.

BEFORE FULLY TIGHTENING ALL SCREWS, CHECK THAT THE SEATS ARE SQUARE BY MEASURING ACROSS THE DIAGONALS. BOTH DIAGONAL MEASUREMENTS SHOULD BE EQUAL.

Please contact us if you need any further help or information.

BRADSHAW PICNIC TABLE

Assembly Guide - 2 of 2

Unit 8C, Top Land Country Business Park
Cragg Road, Mytholmroyd, Hebden Bridge,
West Yorkshire, HX7 5RW
Phone: 01422 419 555
Mail: info@britishrecycledplastic.co.uk

BRITISH
RECYCLED
PLASTIC

