

**PARTS LIST - 2 PERSON ASSEMBLY:-**

A	MOULDED LEG FRAMES	2 no.
B	SEAT AND BACK SLATS NUMBERED 1-7	7 no.
C	90MM STAINLESS STEEL SCREWS	24 no.
D	70MM STAINLESS STEEL SCREWS	4 no.

**TOOLS:-**

POWER DRILL WITH PHILIPS-HEAD BIT
MEASURING TAPE
STRAIGHT EDGE

ALL SEAT SLAT LABELS SHOULD FACE UPWARDS AND BE ON THE LEFT-HAND SIDE WHEN ASSEMBLED.

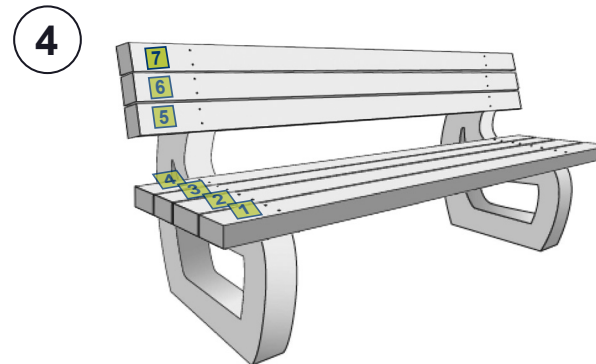
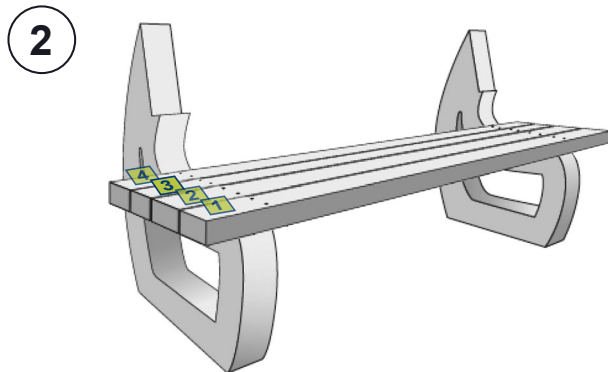
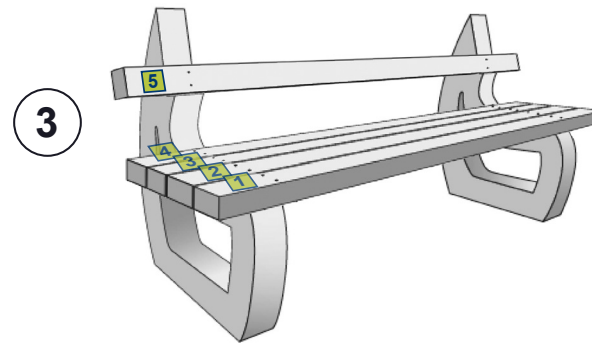
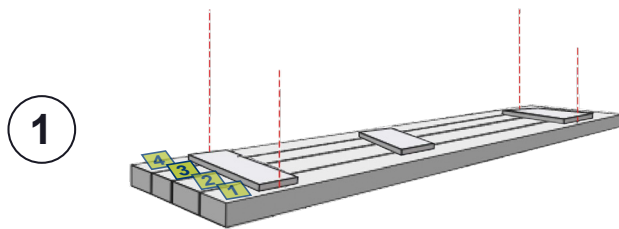
**IMPORTANT:-**

Ensure that you are familiar with these assembly instructions prior to commencing assembly.

We will not accept any claims resulting from products that have been wrongly assembled.

Employ safe lifting procedures when handling components.

**ASSEMBLY.**

USING THE PROVIDED PICTURE GUIDANCE PROCEED WITH STEPS 1-2.

N.B. ALWAYS KEEP SLAT NUMBERS ON THE SAME SIDE.

- POSITION THE 2 MOULDED LEG FRAMES ON A FLAT AND LEVEL SURFACE. POSITION THE FINISHED SEAT SECTION ONTO THE LEG FRAMES. APPLY A 10MM OVERHANG AT FRONT OF SEAT THEN ENSURE THE PRE-DRILLED HOLES LINE UP WITH THE CENTRE OF THE LEG FRAMES. FIX SLAT 1 AT THE FRONT WITH 2 X 70MM SCREWS AND FIX THE REMAINING SLATS WITH 14 X 90MM SCREWS.
- POSITION BACK REST ASSEMBLY ONTO LEGS, ENSURE THE PRE-DRILLED HOLES LINE UP WITH THE CENTRE OF THE LEG FRAME, MATCHING THE SEAT ASSEMBLY. FIX WITH 2 X 50MM SCREWS ON THE TOP 2 HOLES AND FIX THE REMAINING HOLES WITH 90MM SCREWS.

Please contact us if you need any further help or information.

## HAREWOOD BENCH – COLOURED SLATS

Unit 8C, Top Land Country Business Park  
Cragg Road, Mytholmroyd, Hebden Bridge,  
West Yorkshire, HX7 5RW  
Phone: 01422 419 555  
Mail: [info@britishrecycledplastic.co.uk](mailto:info@britishrecycledplastic.co.uk)

BRITISH  
RECYCLED  
PLASTIC

