

PARTS LIST - 2 PERSON ASSEMBLY:-

A	PRE-ASSEMBLED TABLE + FRAME	1 no.
B	PRE-ASSEMBLED SEAT	4 no.
C	M10 x 160mm BOLT	8 no.
D	WASHER	8 no.
E	M10 NUT	8 no.
F	CAP	8 no.

TOOLS:-

HAMMER
17mm SPANNER

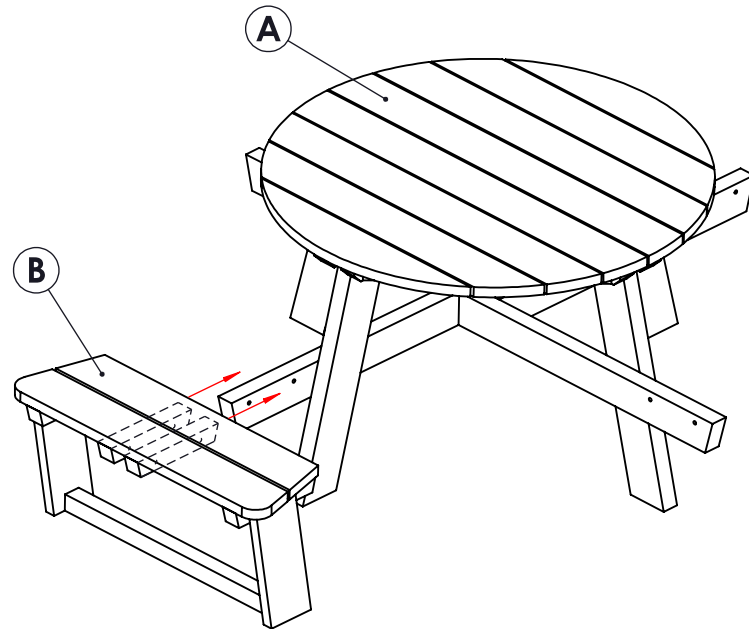

POSITION TIES OF THE PRE-ASSEMBLED SEAT EITHER SIDE OF TABLE'S CROSS-FRAME.

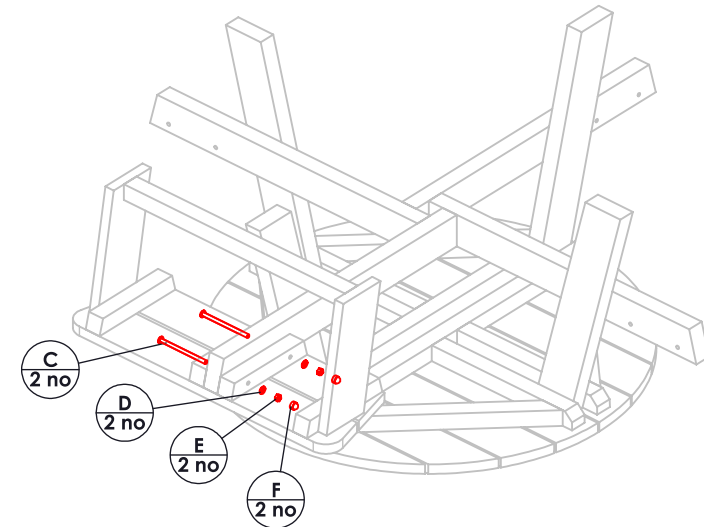

TABLE SHOWN UPSIDE DOWN FOR ILLUSTRATION PURPOSES ONLY.

USING A PROVIDED M10 x 160mm BOLT, FIX THE BOLT THROUGH PRE-DRILLED HOLES IN SEAT TIE AND TABLE FRAME BRACES, ADD WASHER AND NUT AND TIGHTEN UP, COVER NUT WITH BLACK CAP.

IMPORTANT:-

Ensure that you are familiar with these assembly instructions prior to commencing assembly.

We will not accept any claims resulting from products that have been wrongly assembled.

Employ safe lifting procedures when handling components.

Please take care to install your furniture on level ground to ensure it looks its best for decades to come.
Please note that all dimensions are subject to a tolerance of + or - 3%

Please contact us if you need any further help or information.

CALDER PICNIC TABLE**Assembly Guide - 1 of 2**

Unit 8F, Top Land Country Business Park
Cragg Road, Mytholmroyd, Hebden Bridge,
West Yorkshire, HX7 5RW
Phone: 01422 419 555
Mail: info@britishrecycledplastic.co.uk

BRITISH
RECYCLED
PLASTIC



TOOLS:-**HAMMER****17mm SPANNER****IMPORTANT:-**

Ensure that you are familiar with these assembly instructions prior to commencing assembly.

We will not accept any claims resulting from products that have been wrongly assembled.

Employ safe lifting procedures when handling components.

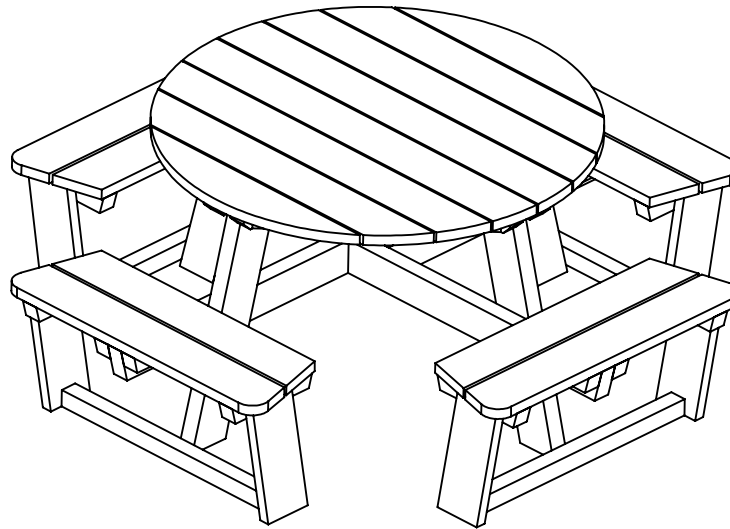

SEAT ASSEMBLY SHOULD NOW BE REPEATED FOR THE REMAINING 3 SEATS, THIS SHOULD FINISH TABLE ASSEMBLY.

Please take care to install your furniture on level ground to ensure it looks its best for decades to come.
Please note that all dimensions are subject to a tolerance of + or - 3%

Please contact us if you need any further help or information.

CALDER PICNIC TABLE**Assembly Guide - 2 of 2**

Unit 8F, Top Land Country Business Park
Cragg Road, Mytholmroyd, Hebden Bridge,
West Yorkshire, HX7 5RW
Phone: 01422 419 555
Mail: info@britishrecycledplastic.co.uk

**BRITISH
RECYCLED
PLASTIC** 