

PARTS LIST - 2 PERSON ASSEMBLY:-

A	PRE-ASSEMBLED RIGHT PANEL	1 no.
B	PRE-ASSEMBLED BACK PANEL 1	1 no.
C	PRE-ASSEMBLED BACK PANEL 2	1 no.
D	PRE-ASSEMBLED LEFT PANEL	1 no.
E	PRE-ASSEMBLED MIDDLE PANEL 1	1 no.
G	TOP TIE	2 no.
H	SLAT - REMOVABLE	10 no.
J	M6 x 90mm BOLT	8 no.
K	WASHER	8 no.
L	NUT	8 no.
M	70mm S/STEEL SCREW	4 no.
N	PRE-ASSEMBLED LID (OPTIONAL)	4 no.

TOOLS:-

POWER DRILL WITH PHILIPS-HEAD BIT

10mm SPANNER

START BY POSITIONING PRE-ASSEMBLED PANELS A,B,C,D,E, AS SHOWN. THEN SLOT THE END OF EACH PANEL INTO THE CHANNEL OF THE CORRESPONDING POST.

USING THE PROVIDED M6 x 90mm BOLT, FIX BOLT THROUGH PRE-DRILLED HOLES, ADD WASHER AND NUT AND TIGHTEN UP.

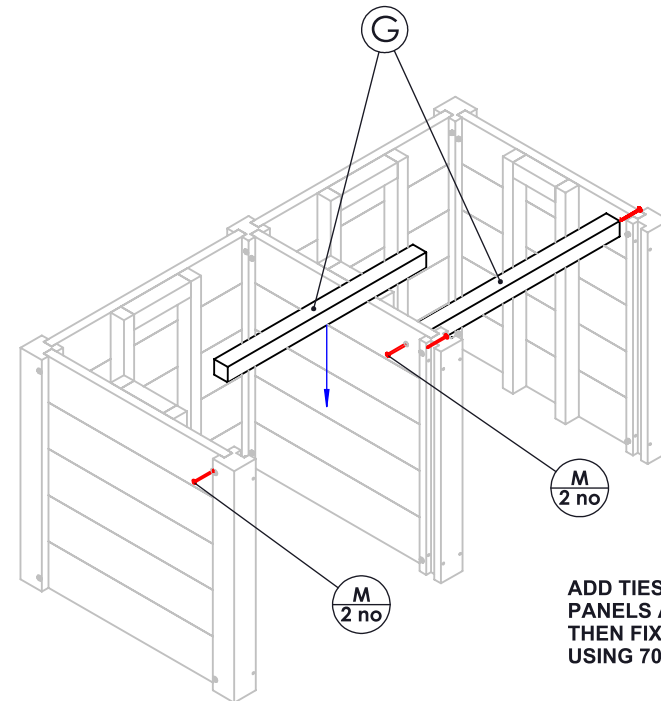
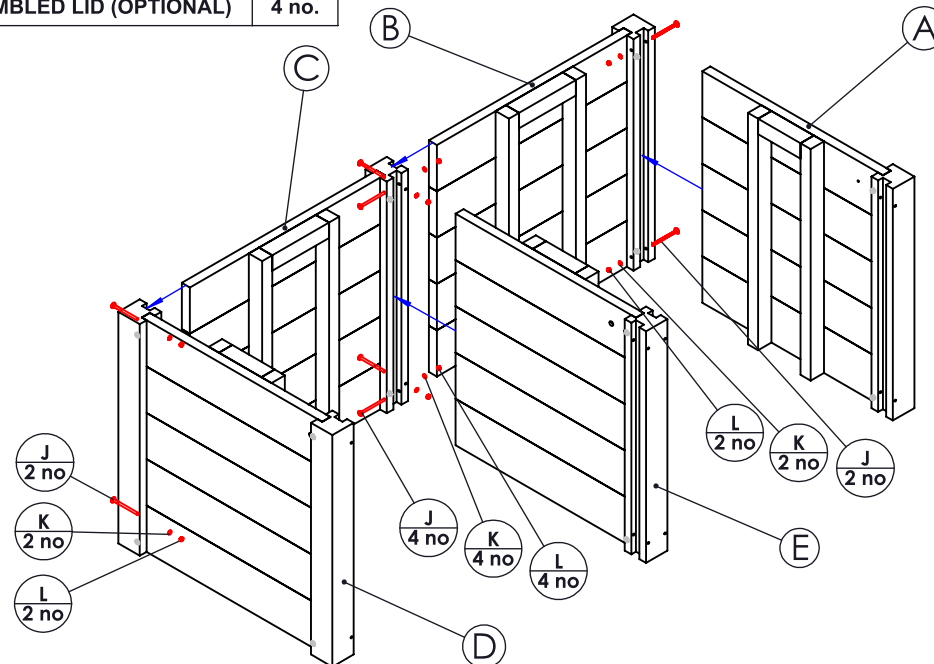
**IMPORTANT:-**

Ensure that you are familiar with these assembly instructions prior to commencing assembly.

We will not accept any claims resulting from products that have been wrongly assembled.

Employ safe lifting procedures when handling components.

Please take care to install your furniture on level ground to ensure it looks its best for decades to come.
Please note that all dimensions are subject to a tolerance of + or - 3%

Please contact us if you need any further help or information.

CALLIS COMPOST BIN – DOUBLE

Assembly Guide - 1 of 2

Unit 8F, Top Land Country Business Park
Cragg Road, Mytholmroyd, Hebden Bridge,
West Yorkshire, HX7 5RW
Phone: 01422 419 555
Mail: info@britishrecycledplastic.co.uk

BRITISH
RECYCLED
PLASTIC



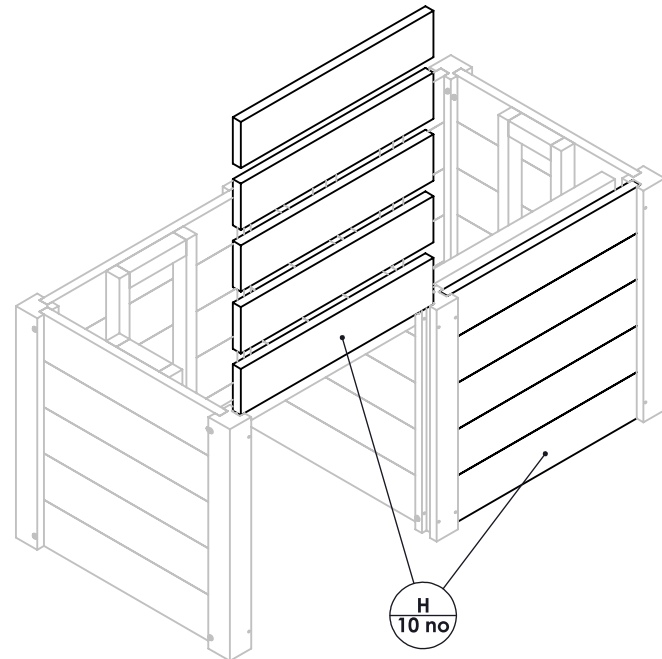

POSITION SLATS AT THE TOP OF THE FRONT POSTS AND SLIDE DOWN BETWEEN THE CHANNELS.

SLATS CAN BE REMOVED TO ALLOW ACCESS TO THE COMPOST AS AND WHEN REQUIRED.

Please take care to install your furniture on level ground to ensure it looks its best for decades to come.
Please note that all dimensions are subject to a tolerance of + or - 3%

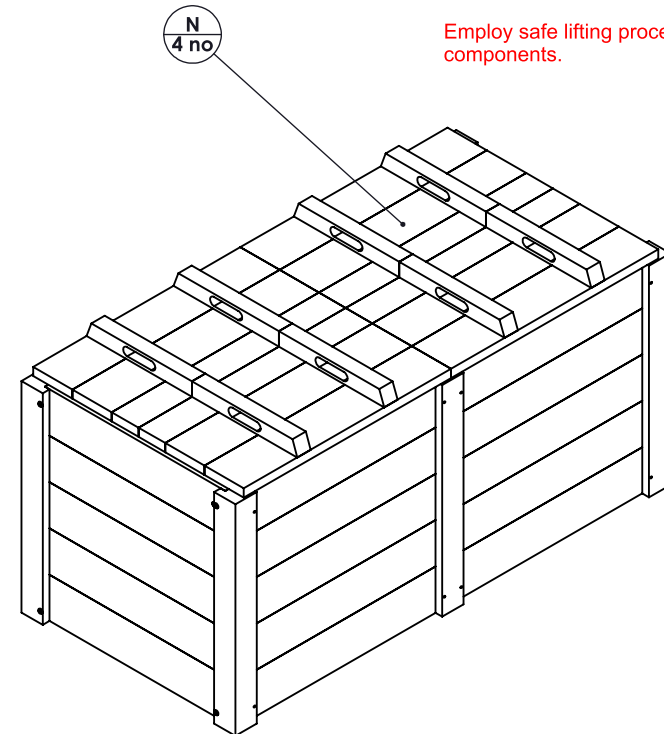

PLACE LIDS* ON TOP OF THE BINS. THIS COMPLETES THE COMPOST BIN ASSEMBLY.

**LIDS ARE AN OPTION AT TIME OF ORDER.*

Please contact us if you need any further help or information.

CALLIS COMPOST BIN – DOUBLE

Assembly Guide - 2 of 2

Unit 8F, Top Land Country Business Park
Cragg Road, Mytholmroyd, Hebden Bridge,
West Yorkshire, HX7 5RW
Phone: 01422 419 555
Mail: info@britishrecycledplastic.co.uk

BRITISH
RECYCLED
PLASTIC 