

**PARTS LIST - 2 PERSON ASSEMBLY:-**

A	BACKLESS LEG FRAMES	2 no.
B	3 SLAT SEAT SEMI-ASSEMBLED	1 no.
C	70mm S/STEEL SCREWS	4 no.
D	90mm S/STEEL SCREWS	8 no.

**TOOLS:-**

POWER DRILL WITH PHILIPS-HEAD BIT  
MEASURING TAPE & STRAIGHT EDGE

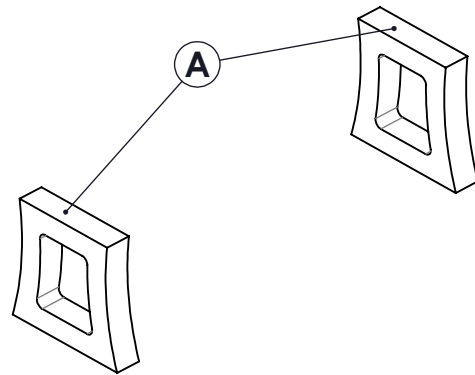

POSITION THE 2 MOULDED BACKLESS LEG FRAMES ON A FLAT LEVEL SURFACE

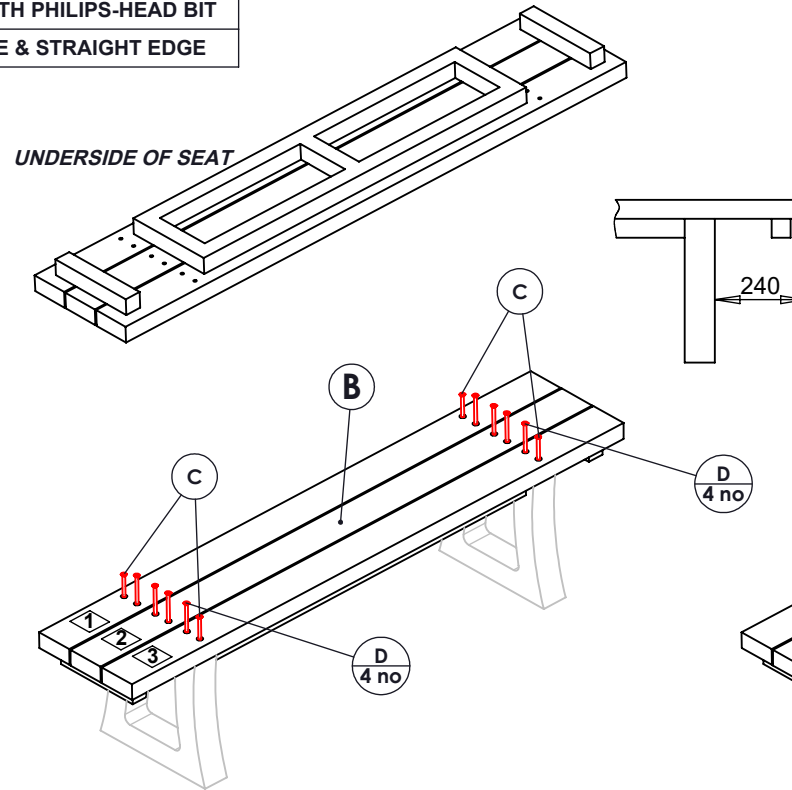

ALL SEAT SLAT LABELS SHOULD FACE UPWARD AND BE ON THE LEFT-HAND SIDE WHEN ASSEMBLED

POSITION THE FINISHED SEAT SECTION ONTO THE LEG FRAMES, LEG FRAMES SHOULD BUTT AGAINST SUB FRAME, APPLY A 10mm OVERHANG AT FRONT OF SEAT. ENSURE THE PRE-DRILLED SLAT HOLES LINE UP WITH THE CENTRE OF THE LEG. FIX WITH 2 x 70mm S/STEEL SCREWS ON OUTSIDE FIXING HOLES ON BOTH SIDES OF SEAT SLATS. THE REMAINDER OF THE HOLES ARE TO BE FIXED WITH 8 x 90mm S/STEEL SCREWS

**IMPORTANT:-**

Ensure that you are familiar with these assembly instructions prior to commencing assembly.

We will not accept any claims resulting from products that have been wrongly assembled.

Employ safe lifting procedures when handling components.

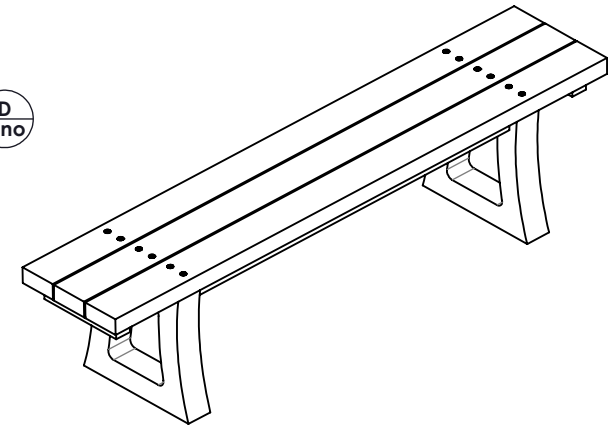

THIS COMPLETES THE BENCH ASSEMBLY

Please take care to install your furniture on level ground to ensure it looks its best for decades to come.  
Please note that all dimensions are subject to a tolerance of + or - 3%

Please contact us if you need any further help or information.

**OAKWORTH BENCH****Assembly Guide**

Unit 8F, Top Land Country Business Park  
Cragg Road, Mytholmroyd, Hebden Bridge,  
West Yorkshire, HX7 5RW  
Phone: 01422 419 555  
Mail: info@britishrecycledplastic.co.uk

BRITISH  
RECYCLED  
PLASTIC

