

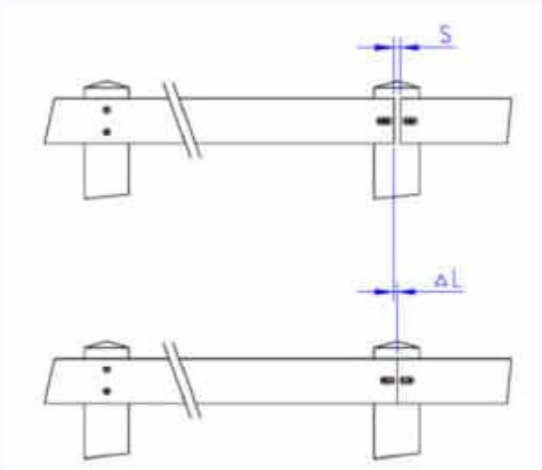

ISO 9001 Certified | Made in the UK from 100% Recycled Plastic | 25 Year Guarantee

Technical Information for Using British Recycled Plastic for Fencing and Plastic Fence Posts



Recycled plastic artificial lumber expands and contracts around 5mm per metre for every 10 degrees Celsius change over around 12 degrees.

Please allow for this by creating a 10mm – 15mm expansion gap between rail ends inside post joint and when drilling rails to posts.

Drill holes should be slightly oversized (by approximately 3mm) to accept screws or, as an alternative method, insert a 10mm slot which will allow movement in the fencing.

Fully tighten all screws and then back screw half a turn anti-clockwise.

Use standard 3.1 metre lengths of rail by staggering the rail joints 1 metre to 1.55 metres (maximum) between posts. Rails should be fixed through the central post, for mortised types, to allow the two ends to float for expansion and contraction. Always pre-drill to prevent splitting and screw bolt together wherever possible.

Unit 8F Top Land Country Business Park, Mytholmroyd, West Yorkshire, HX7 5RW



ISO9001
Certified



ISO 9001 Certified | Made in the UK from 100% Recycled Plastic | 25 Year Guarantee

Posts:

General fencing such as post and rail – All posts 100mm square x height required and an additional one third for below ground fixing. The general rule is two thirds above ground and one third below.

Birdsmouth (Knee Rail) fencing – 80mm square x 3100mm long or 100mm square x 3100mm long with a V cut.

We recommend that post centres should be no more than 1500mm although 1000mm is even better.

Rails

Either 50mm x 100mm or 50mm x 120mm rails for post and rail types that will either be face fixed or mortised. 40mm x 100mm or 40mm x 120mm rails for picket and pale or close board types and for Birdsmouth / knee rail types, 100mm square rails.

Pales

Use either 20x 100mm (available in 1200mm or 1800mm only), or 30mm x 100mm or 30mm x 150mm

Unit 8F Top Land Country Business Park, Mytholmroyd, West Yorkshire, HX7 5RW



ISO9001
Certified

